

For more  
Information  
please scan QR Code

Für weiterführende  
Informationen scannen  
sie bitte den QR Code

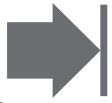

scan



or go online:  
[ja-eba.de/b4637959](http://ja-eba.de/b4637959)



**HOTLINE** +49 5246 921019  
[support@jaeger-automotive.de](mailto:support@jaeger-automotive.de)

**JAEGER**  
automotive

## INFORMATION SHEET

Old module (14-Pin)  
Altes Modul (14-polig)  
Stary moduł (14-pin)  
Starý modul (14-pin)



New module (16-Pin)  
Neues Modul (16-polig)  
Nowy moduł (16-pin)  
Nový modul (16-pin)

1.

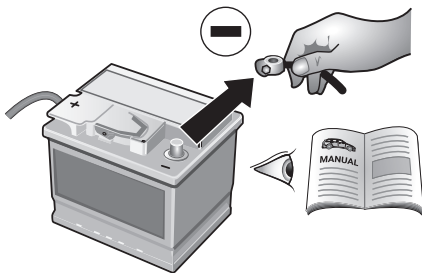

3. Open secondary lock!

Sekundärverriegelung

öffnen!

Otworzyć zabezpieczenie!

Otvoriť aretáciu!

4. Note the positions of all wire colours.

Notieren Sie die Positionen aller Kabelfarben.

Zwróć uwagę na pozycje wszystkich kolorów przewodów.

Poznačte si pozície všetkých farieb vodičov.

2.

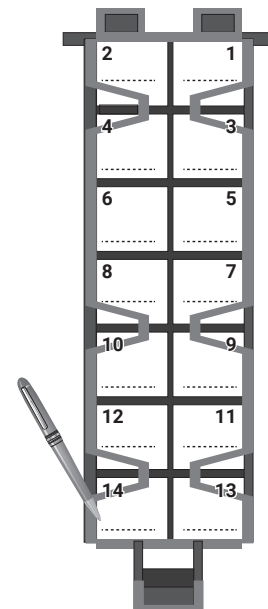
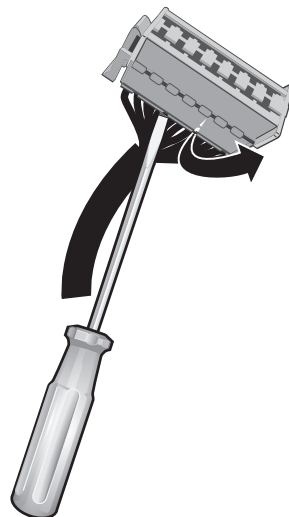
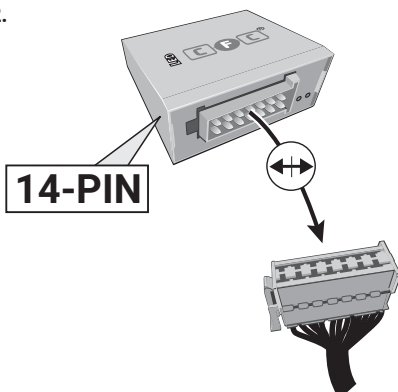

5. Remove terminals of all wires out of the 14-pin connector ...

Entfernen Sie die Kontakten aller Leitungen aus dem 14-poligen Stecker ...

Wymij j końcówki wszystkich przewodów od 14-stykowego złącza ...

Vyberte všetky vodiče zo 14-pinového konektora ...

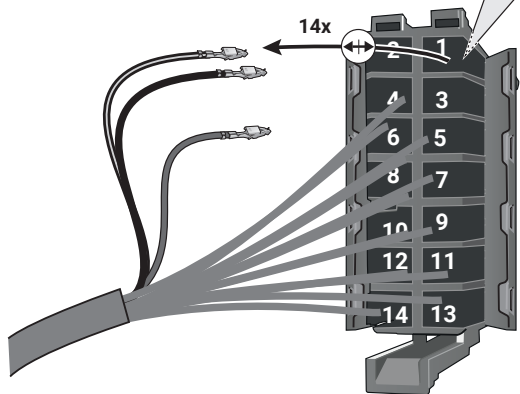
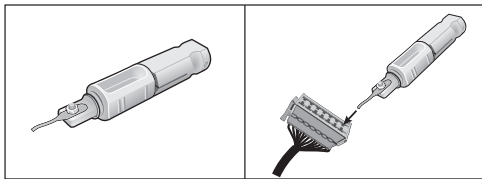

6. ... and insert them into the 16-pin connector!

Please consider the noted cable colours from step 4!

... und in den 16-poligen Stecker stecken!

Bitte beachten Sie die notierten Kabelfarben aus Schritt 4!

... i włożyć je do 16-stykowego złącza!

Należy wziąć pod uwagę kolory przewodów podane w kroku 4!

... a vložit je do 16-pinového konektora!

Dbajte pritom na farby vodičov zaznamenané v kroku 4!

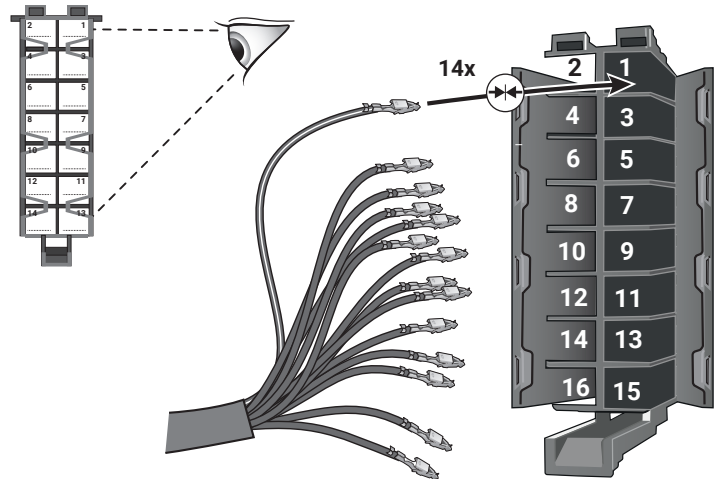

7. Close secondary lock!

Sekundärverriegelung schließen!

Zamknac zabezpieczenie!

Uzavrieť aretáciu!

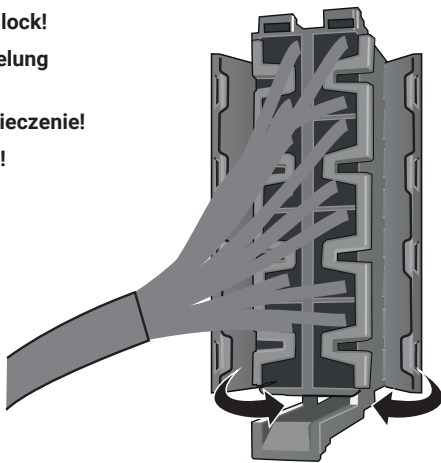

8.

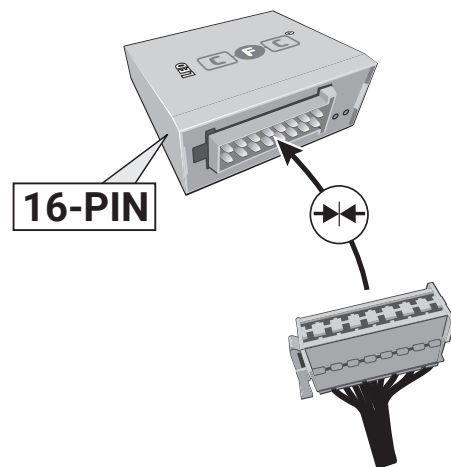

9.

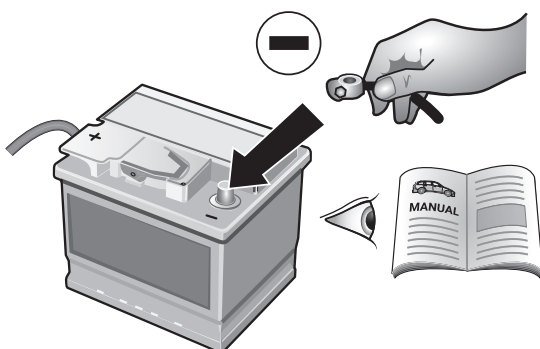

10.

